

# Protecting Data with Thales Key Management and Dell VxRail HCI System



## The Challenge

The challenges inherent in securing IT data environments today are multiple:

- Increase in regularity and sophistication of data breaches
- Data privacy/compliance mandates (e.g. FIPS, HIPAA, GDPR, PCI-DSS, etc.)
- Cost control
- Rapid digital transformation
- Explosive data growth

To meet these challenges, a data-centric solution that reliably secures sensitive data as it moves from endpoints through networks to applications and the cloud is required. Data protection through proven encryption and centralized, scalable management of encryption keys is the last bastion of protection. Fortunately, Thales and Dell integrated solutions work at a lower total cost of ownership (TCO) to provide comprehensive data security and enable compliance in today's environment.

## The Solution

Using the industry standard Key Management Interoperability Protocol (KMIP), Dell VxRail HCI systems integrate with Thales enterprise key management (EKM) to mitigate the threat of unauthorized access to encrypted data, at vSAN or VM-level (see Fig. 1, below). Thales EKMs provide security by storing and managing keys away from encrypted devices and data, thus securing keys (and, thereby, data) even if the storage system is compromised.

There are two Thales EKMS deployment options available

- **Encryption at the VM level:** (see Fig. 2) Encryption of the entire VM, including all the files within the container. Everything remains encrypted, even as VMs are moved and re-deployed. Requires one KMIP license per vCenter server. Thales Luna Hardware Security Module (HSM) maintains Root of Trust (RoT) security as it provides data encryption key pairs for each VM. Higher security than VSAN-level encryption. Deduplication and compression is not available with this deployment option.
- **Encryption at the VMWare vSAN level:** (see Fig. 3) Each virtual disk in the vSAN is encrypted, protecting all data at rest. Requires one KMIP license per server and one license per ESXi server. Luna HSM provides secure data encryption key pairs per virtual disk. This deployment option enables the addition of deduplication and compression.

Additionally, Thales EKM simplifies and centralizes encryption key policies and management and enables regulatory compliance through:

- role-based access control to keys and policies
- multi-tenancy support with ultimate separation of duties
- robust auditing and reporting of all key management operations
- Root of Trust security available through a portfolio of Hardware Security Modules (HSM), with internal and external models that offer options of FIPS compliance Level 1, 2 or 3
- support for turnkey encryption at application, file, data, or database level. Support for data within VM and Container

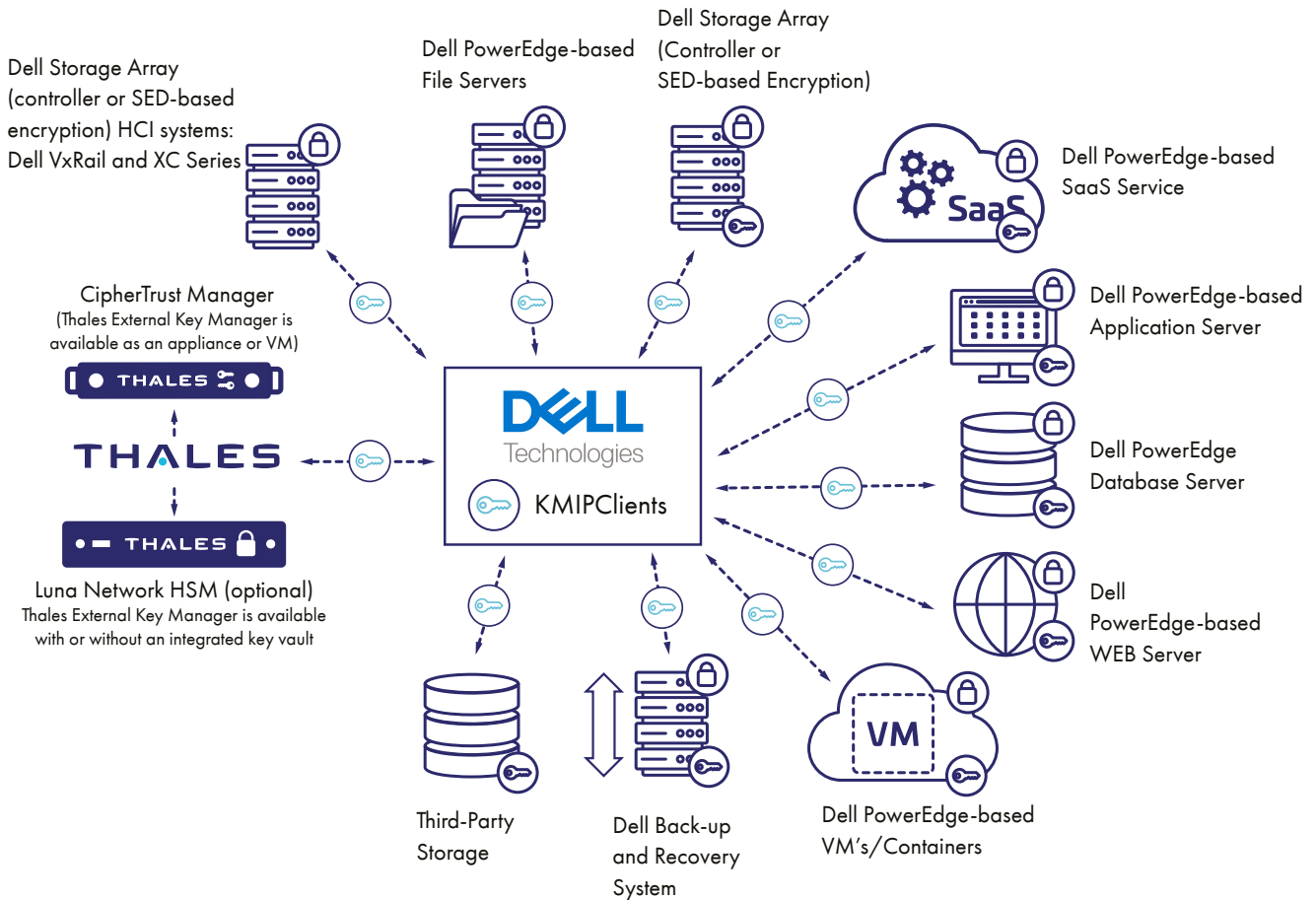

Fig. 1 - Thales Enterprise Key Management solutions and DELL and 3rd party platforms

## Security at a Lower Total Cost of Ownership (TCO)

With Thales and Dell, the cost of key management is distributed amongst multiple appliances, rendering the prohibitive cost of expensive, dedicated point products with disparate features and user interfaces a thing of the past. Whether the data is stored in applications, databases, files, virtual machines (VMs), containers, or storage appliances, Thales EKM lowers the cost of key management and encryption through centralized administration and automated operations across multiple encryption deployments and products. Thales EKM reduces the additional staff and time it takes to integrate and manage multiple systems, minimizing complexity, costs and the chance for user errors to contribute to the breach of valuable data. Thales EKM protects data across the entire organization in a central, automated, uniform and repeatable way, freeing IT staff and budget for the next security challenge and new compliance requirement.

## Key Capabilities

- Centralized Key Management with the Largest Ecosystem of Partners. Centralized key management for multiple on-premises data stores and cloud infrastructures.
- Full Key Lifecycle Management and Policy Driven Automated Operations: Simplifies management of encryption keys, automates policy-driven operations and generates custom alarms

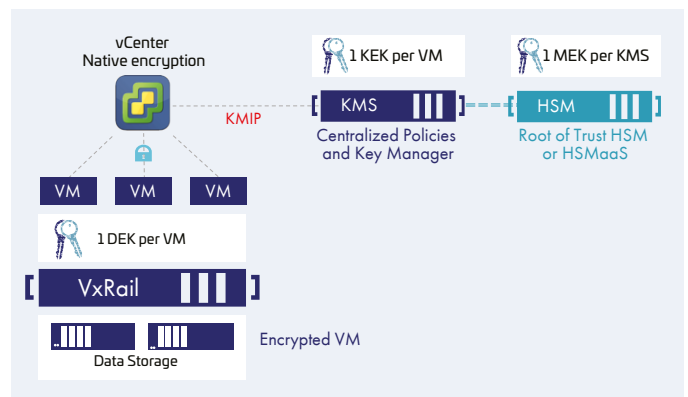

Fig. 2 Encryption at the VM level

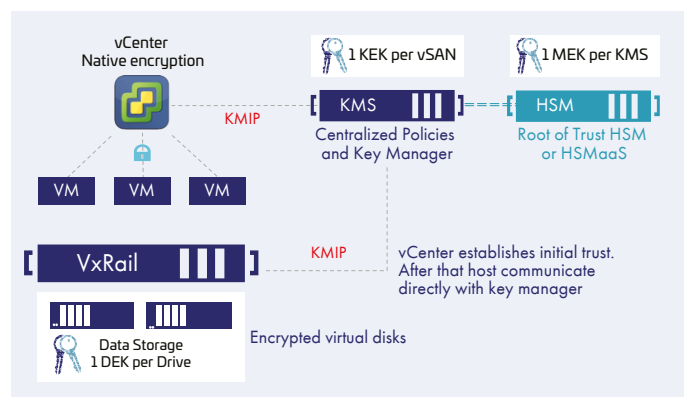

Fig. 3 Encryption at the VMware vSAN level

- Centralized Administration and Role-Based Access Control: Role-based access control using existing AD and LDAP credentials
- Robust Non-Repudiation Auditing and Reporting (integrates with popular SIEM tools): Track all key state changes, administrator access, and policy changes in multiple log formats (RFC-5424, CEF, LEEF) allowing easy integration with popular SIEM tools. Generates customizable email-based alerts.
- High Availability Clustering. Supports high availability to mission-critical workloads
- Multi-tenancy support. Ideal for a large organization with a distributed location or service provider
- High-speed Interfaces with NIC Bonding Optional 2x1GB/2x10GB network interface cards (NIC) as well as NIC bonding to increase available bandwidth.
- Password and PED Authentication: Choice of password or PIN Entry Device (PED) authentication

#### Available Thales EKMs

Thales Enterprise Key Management Platforms		
Features	Physical Appliances	Virtual Appliances
<b>Max Keys</b>	1,000,000	25,000
<b>Max concurrent clients per cluster</b>	1,000	1,000
<b>FIPS 140-2 Support*</b>	Level 1 or 2 Level 3 with an external or build-in HSM	Level 1 Level 2 or 3 with an external HSM
<b>Supports the SafeNet Data Protection Portfolio</b>	Yes	Yes
<b>Redundant hotswap HDs &amp; Power</b>	Yes	N/A
<b>Example of Thales Offering</b>	CipherTrust Manager K470 (without HSM), K570 (with HSM), CipherTrust Manager V6000 (without HSM) and V6100 (with HSM)	CipherTrust Manager K170V, CipherTrust Manager virtual version

## About Thales

The people you rely on to protect your privacy rely on Thales to protect their data. When it comes to data security, organizations are faced with an increasing number of decisive moments. Whether the moment is building an encryption strategy, moving to the cloud, or meeting compliance mandates, you can rely on Thales to secure your digital transformation.

Decisive technology for decisive moments.

## About Dell Technologies

Dell Technologies (NYSE:DELL) helps organizations and individuals build their digital future and transform how they work, live and play. The company provides customers with the industry's broadest and most innovative technology and services portfolio for the data era.